

www.teknikoffice.co.uk

Teknik

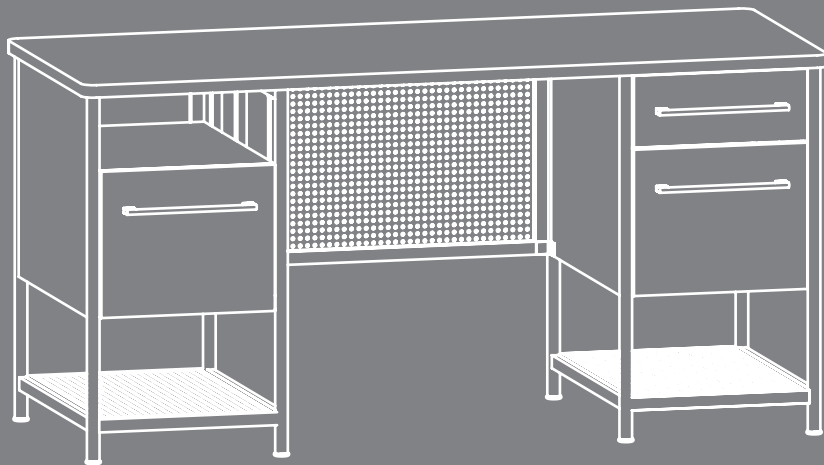

Sit and surf.

Boulevard Cafe Desk

Model 5420701

NOTE: THIS INSTRUCTION BOOKLET CONTAINS **IMPORTANT** SAFETY INFORMATION.

PLEASE READ AND KEEP FOR FUTURE REFERENCE.

Table of Contents

Assembly Tools Required

Part Identification	3
Hardware Identification	4
Assembly Steps	5-18

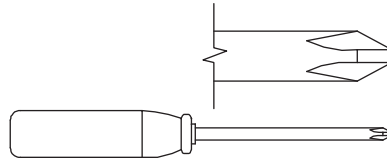

No. 2 Phillips Screwdriver
Tip Shown Actual Size

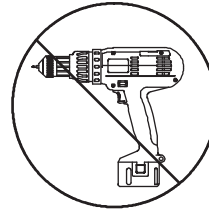

Skip the power trip.
This time.

Part Identification

Now you know
our ABCs.



While not all parts are labeled, some of the parts will have a label or an inked letter on the edge to help distinguish similar parts from each other. Use this part identification to help identify similar parts.

S	RIGHT END (1)	Y	BACK (2)	EE	SMALL DRAWER BACK (1)
T	LEFT END (1)	Z	SHELF (1)	FF	SMALL DRAWER BOX FRONT (1)
U	RIGHT UPRIGHT (1)	AA	MODESTY PANEL (1)	GG	DRAWER BOTTOM (3)
V	LEFT UPRIGHT (1)	BB	SMALL DRAWER FRONT (1)	HH	LARGE DRAWER SIDE (4)
W	TOP (1)	CC	LARGE DRAWER FRONT (2)	JJ	LARGE DRAWER BACK (2)
X	BOTTOM (2)	DD	SMALL DRAWER SIDE (2)	KK	LARGE DRAWER BOX FRONT (2)

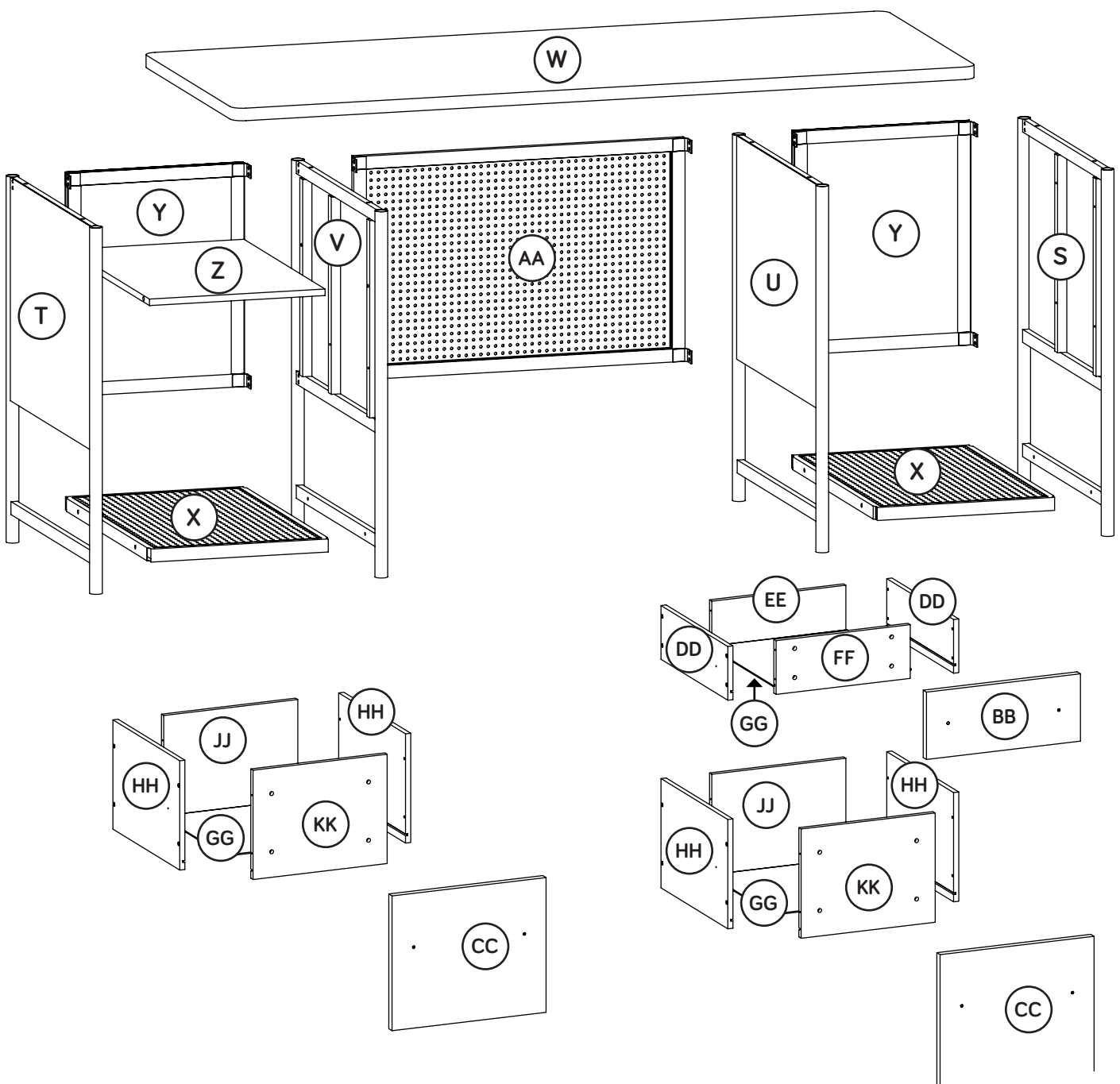

Hardware Identification

† Screws are shown actual size. You may receive extra hardware with your unit.

(EXTENSION SET SHOWN SEPARATED)

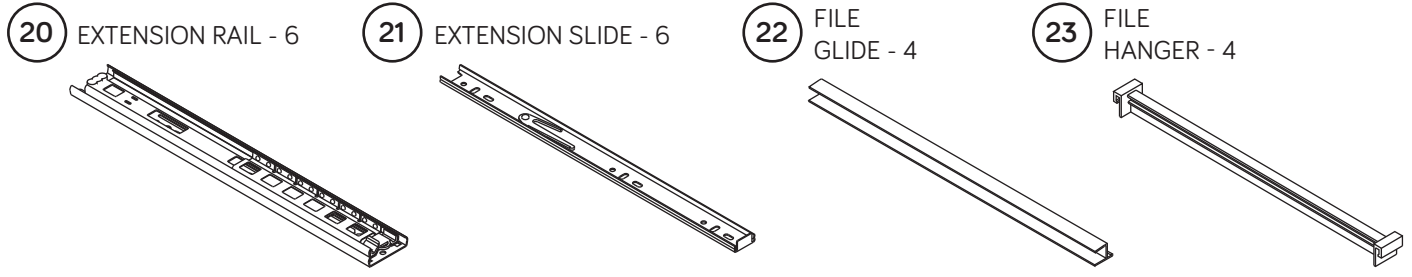

Step 1

- ✚ Assemble your unit on a carpeted floor or on the empty carton to avoid scratching your unit or the floor.
- ✚ Fasten the LEFT END (T) and one BACK (Y) to the TOP (W). Use four BLACK 1-1/2" FLAT HEAD SCREWS (28).
- ✚ Fasten the BACK (Y) to the LEFT END (T). Use two BLACK 3/8" MACHINE SCREWS (34).

 Remember:
Righty tighty.
Lefty loosey.

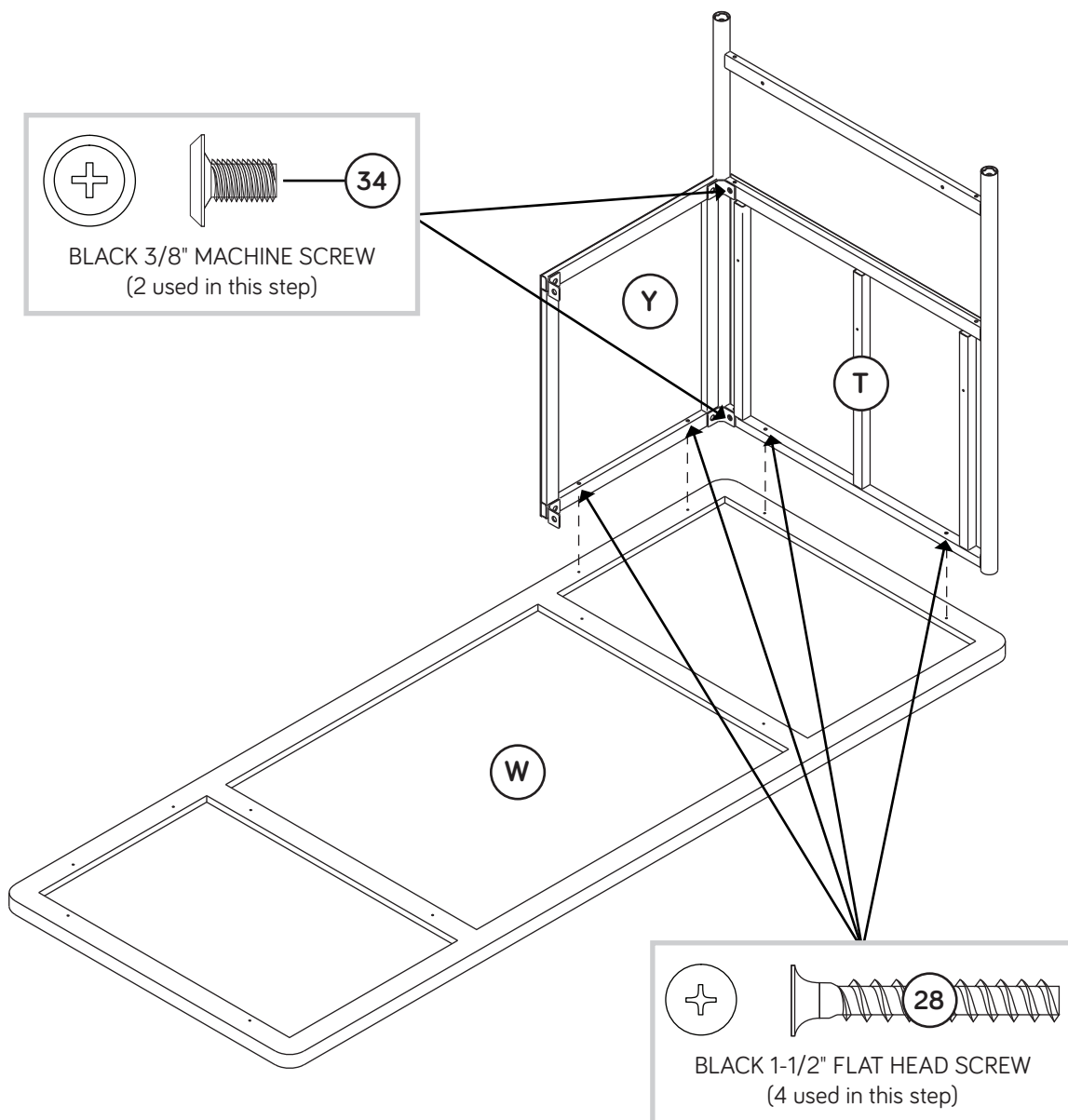

Step 2

- Fasten the LEFT UPRIGHT (V) to the TOP (W). Use two BLACK 1-1/2" FLAT HEAD SCREWS (28).
- Fasten the BACK (Y) to the LEFT UPRIGHT (V). Use two BLACK 3/8" MACHINE SCREWS (34).

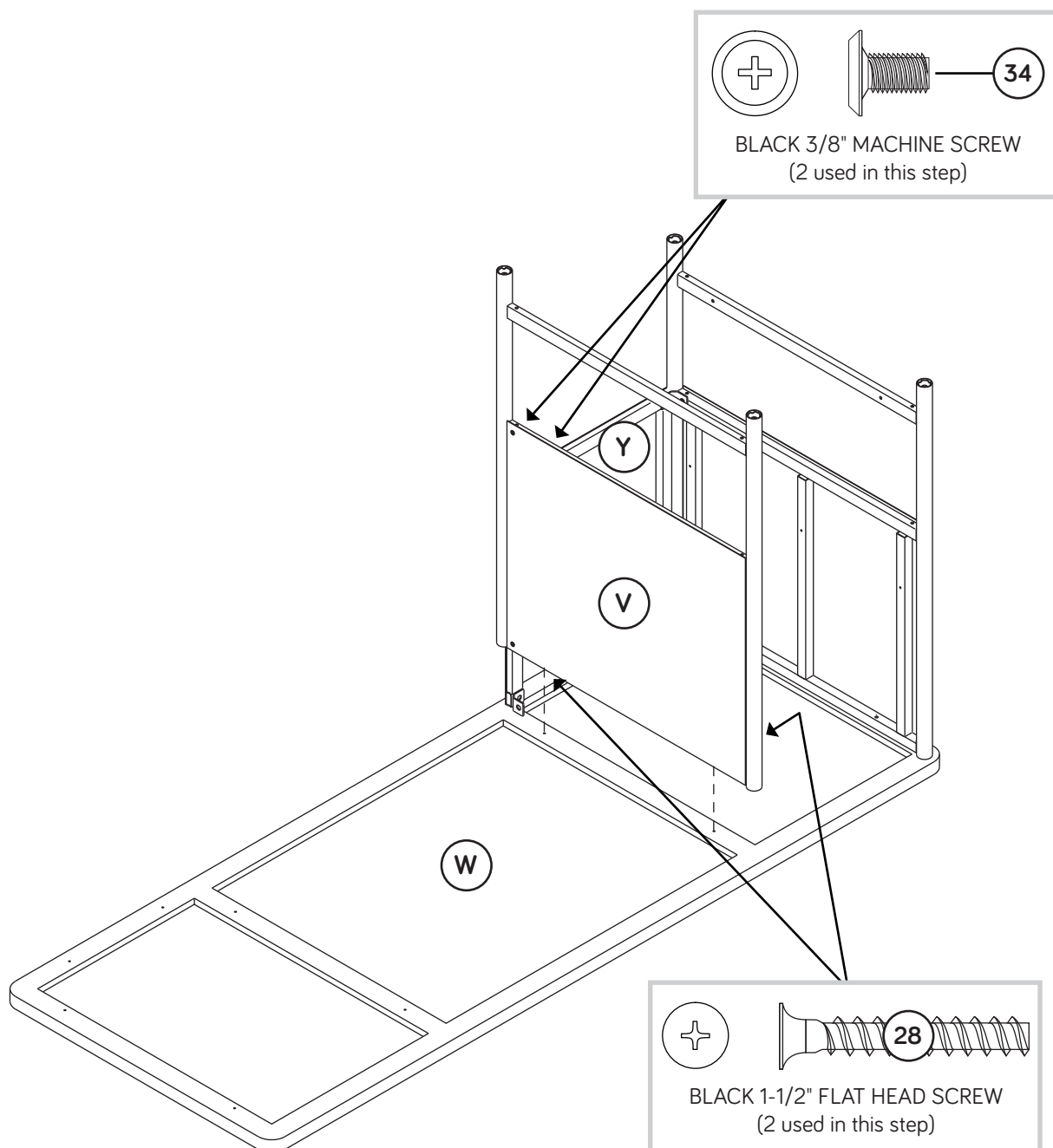

Step 3

- Fasten the MODESTY PANEL (AA) to the LEFT UPRIGHT (V).
Use two BLACK 3/8" MACHINE SCREWS (34).

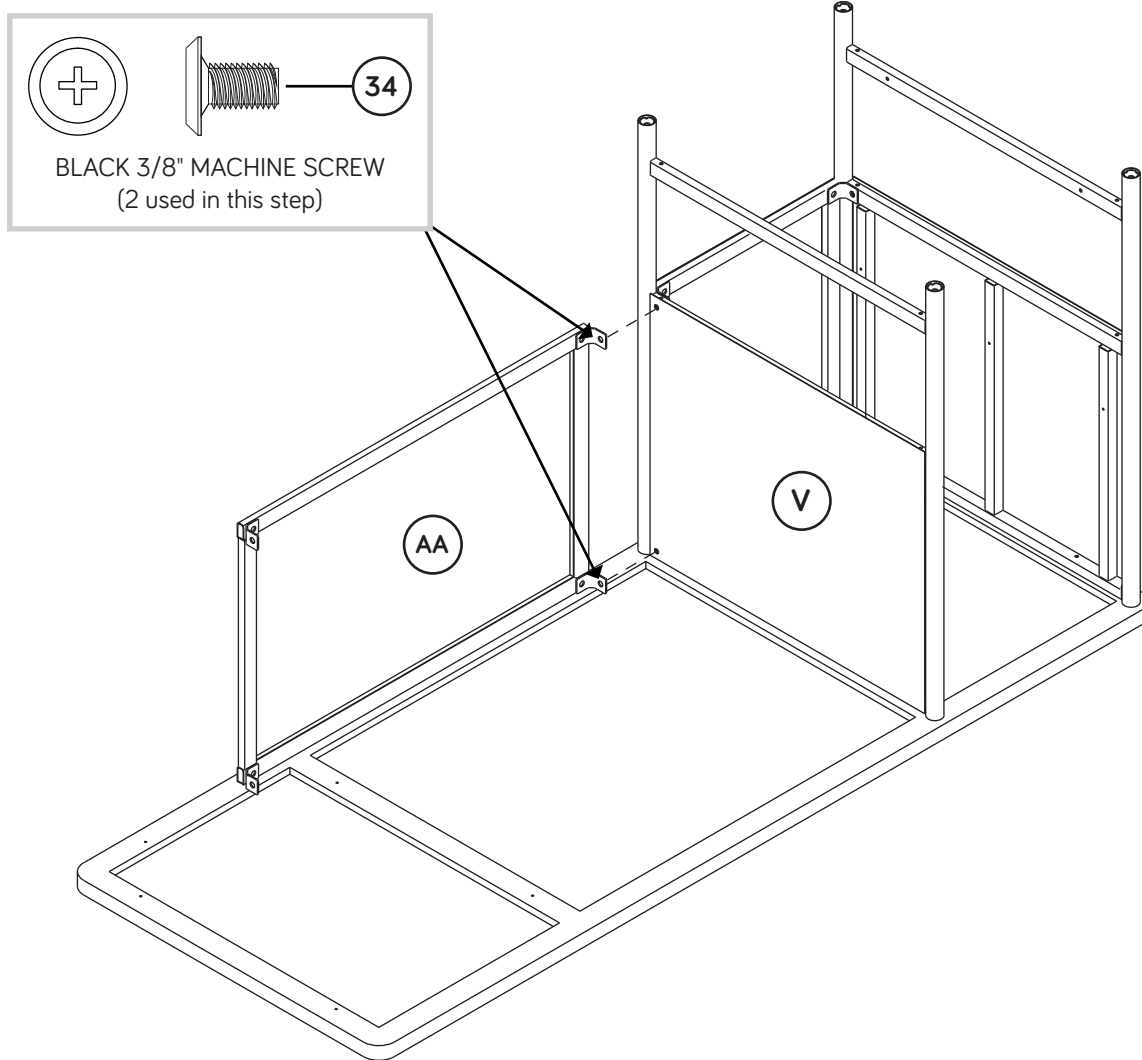

Step 4

- Fasten the RIGHT UPRIGHT (U) to the TOP (W). Use two BLACK 1-1/2" FLAT HEAD SCREWS (28).
- Fasten the MODESTY PANEL (AA) to the RIGHT UPRIGHT (U). Use two BLACK 3/8" MACHINESCREWS (34).

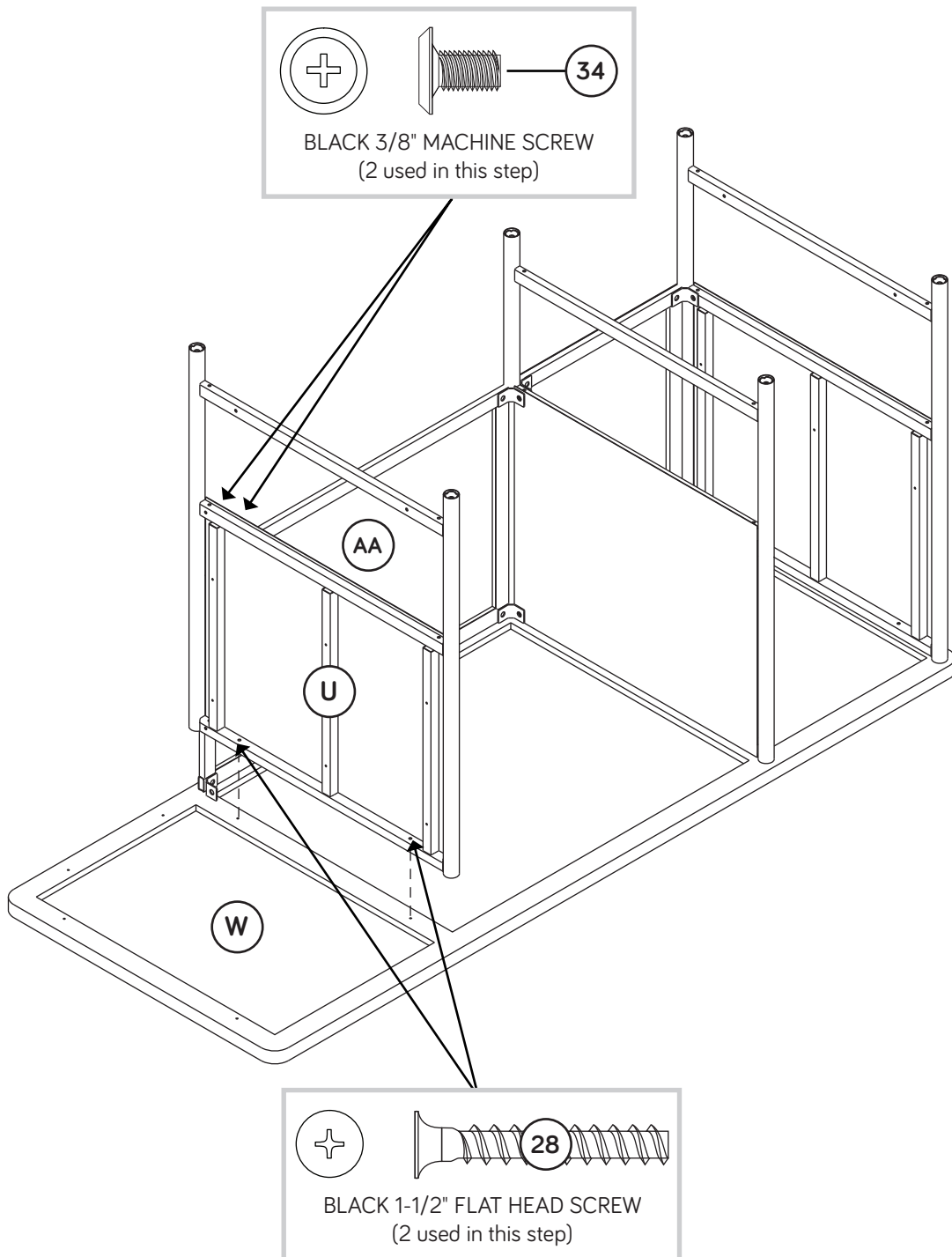

Step 5

- Fasten the RIGHT END (S) and remaining BACK (Y) to the TOP (W). Use four BLACK 1-1/2" FLAT HEAD SCREWS (28).
- Fasten the BACK (Y) to the RIGHT END (S) and RIGHT UPRIGHT (U). Use four BLACK 3/8" MACHINE SCREWS (34).

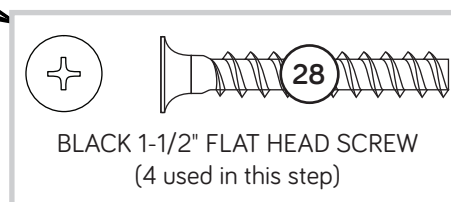
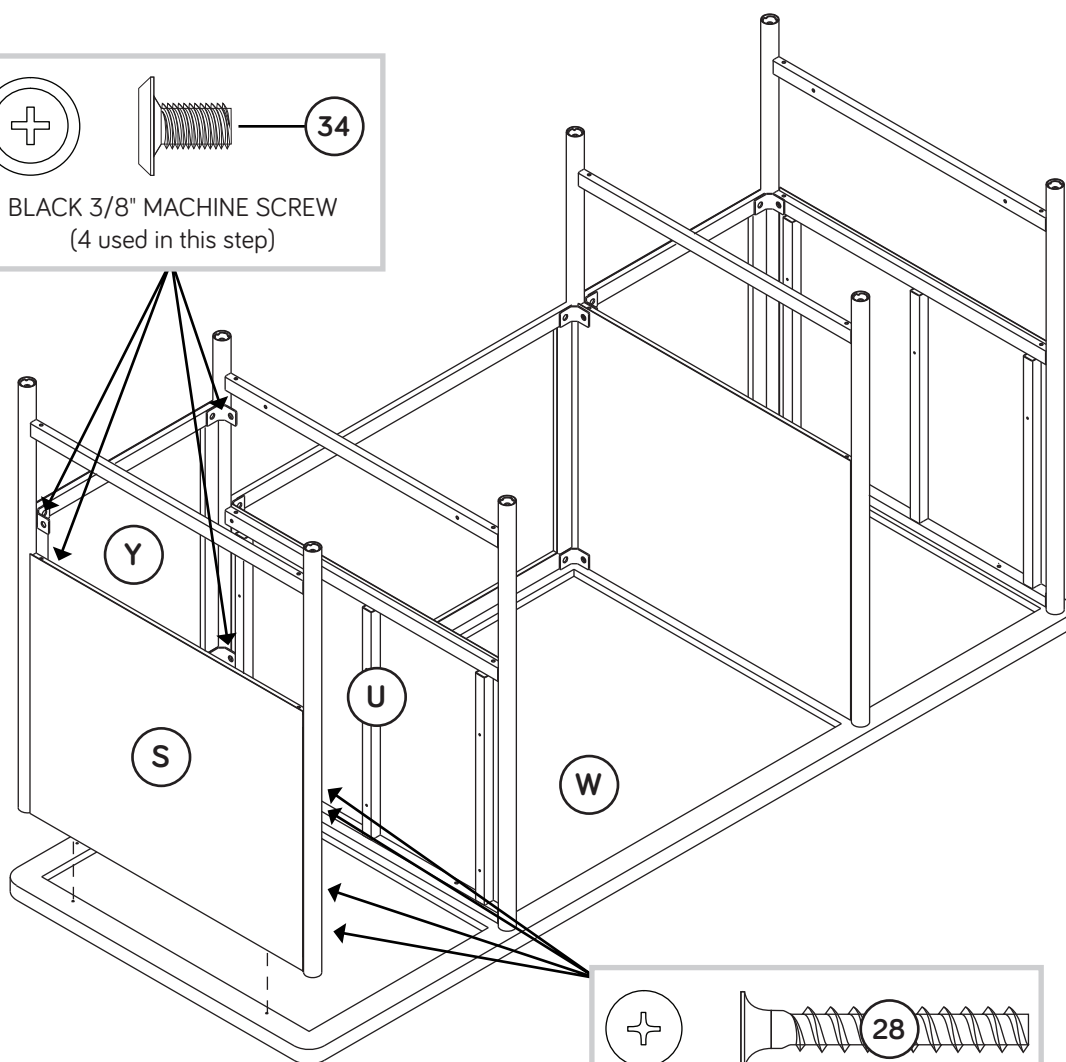
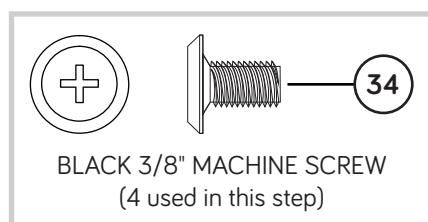

Step 6

Fasten the SHELF (Z) to the LEFT END (T) and LEFT UPRIGHT (V). Use four BLACK 3/8" MACHINE SCREWS (34).



Now might be a good time to refresh your drink.

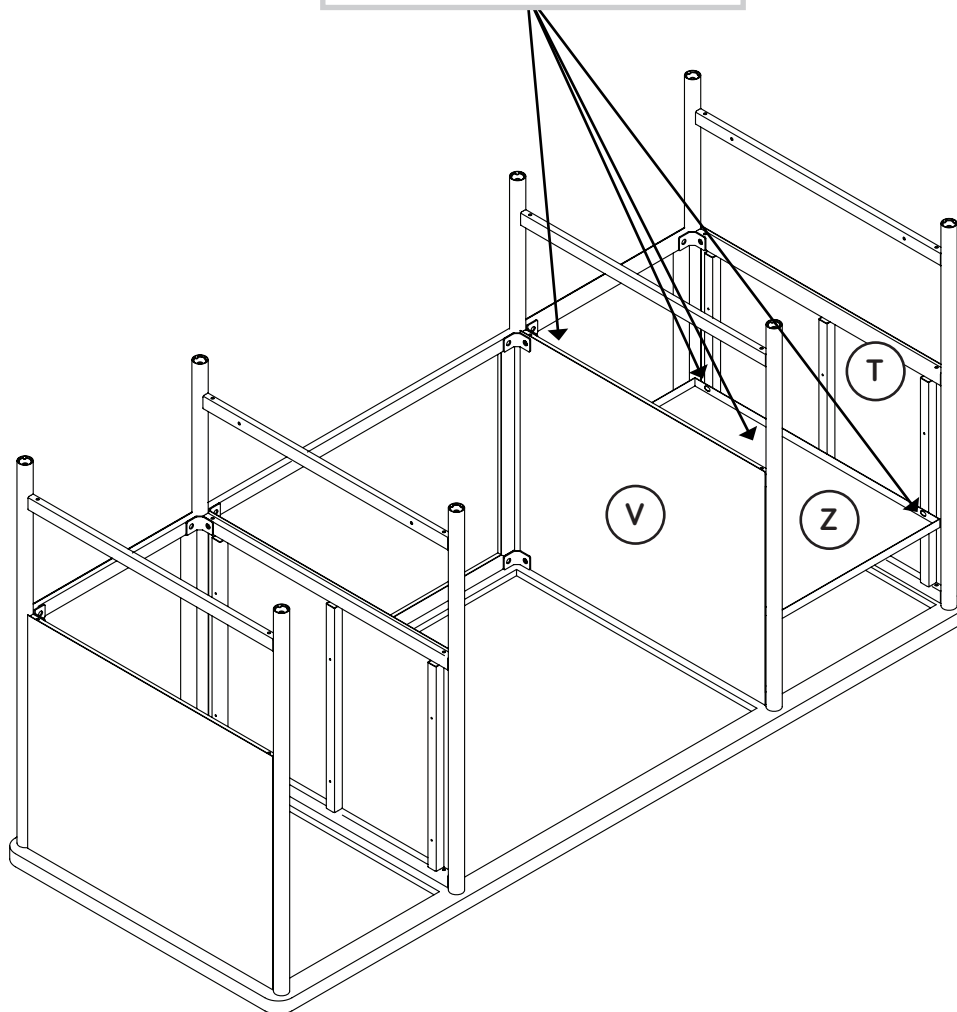
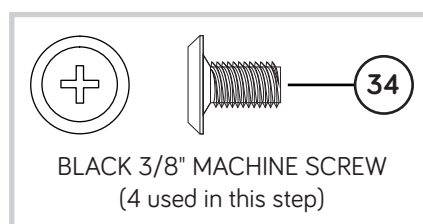

Step 7

- Fasten the BOTTOMS (X) to the ENDS (S and T) and UPRIGHTS (U and V). Tighten eight BLACK 1" HEX HEAD SCREWS (29) using the L-WRENCH (26).

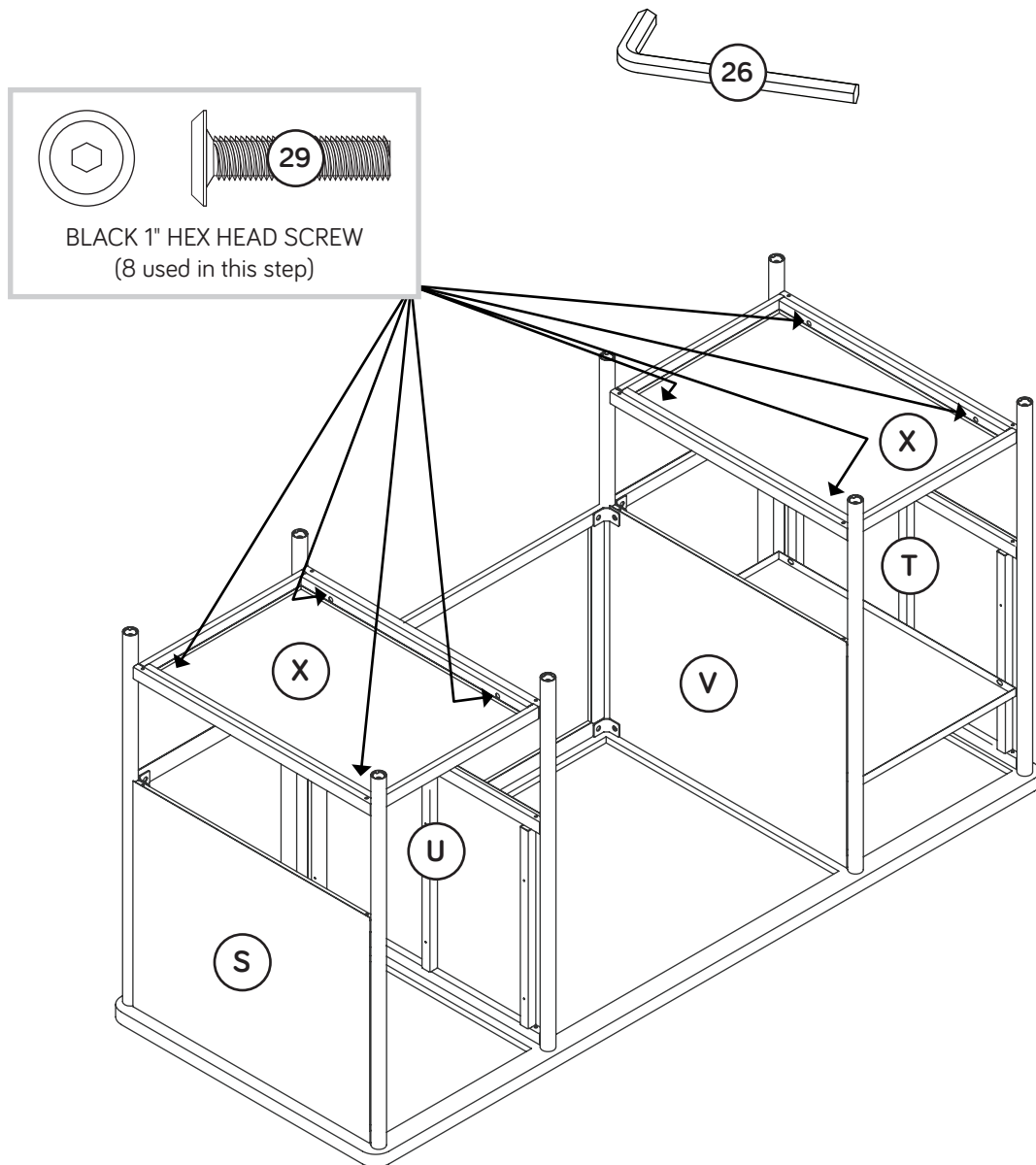

Step 8

- ✚ **IMPORTANT:** Be sure to keep SCREWS (32) separate from SCREWS (33). Do not confuse these SCREWS.
- ✚ Separate the EXTENSION SLIDES (21) from the EXTENSION RAILS (20) as shown in the upper diagram below. Be prepared, the parts are greasy.
- ✚ Fasten the EXTENSION RAILS (20) to the ENDS (S and T) and UPRIGHTS (U and V). Use twelve LARGE BLACK 1/2" FLAT HEAD SCREWS (32).
- ✚ **NOTE:** For each EXTENSION RAIL, turn a SCREW into the 1st hole shown in the diagram. Then, slide the inner cartridge of the EXTENSION RAIL in to find the other hole that lines up with the hole in the END/UPRIGHT. Turn a SCREW into this hole.
- ✚ **NOTE:** The EXTENSION SLIDES will be used later for the DRAWERS.

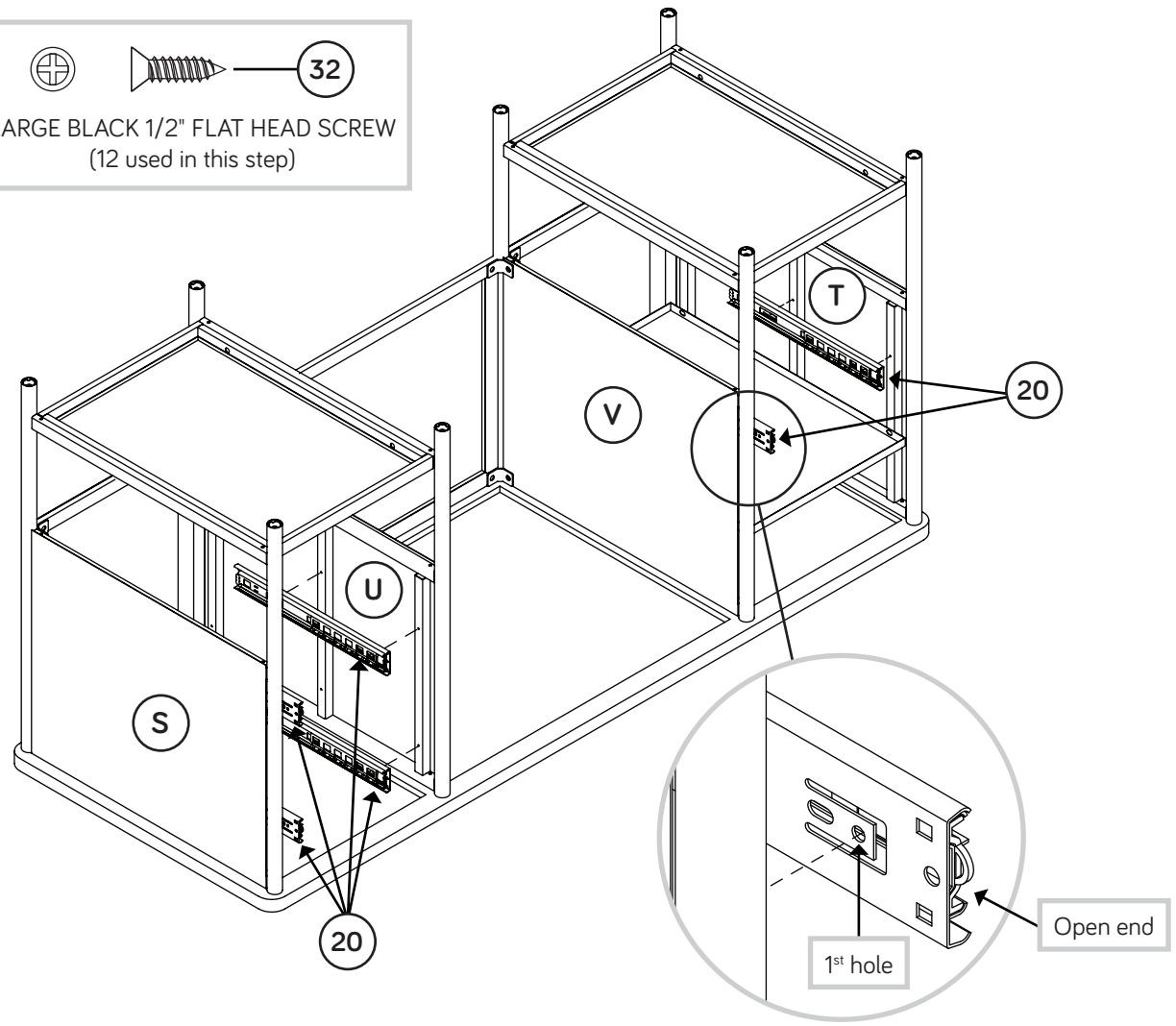
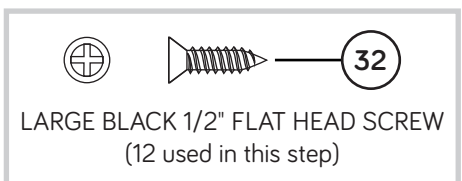
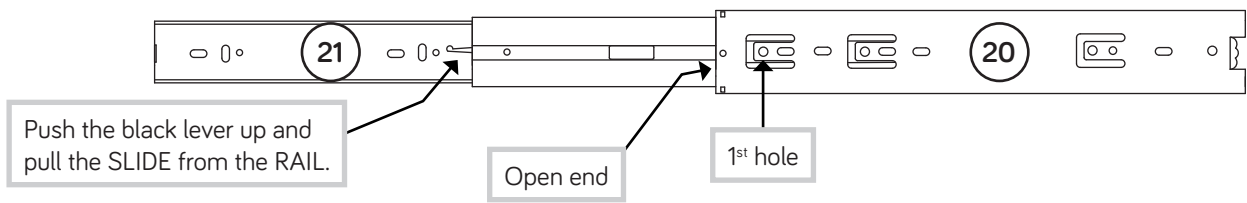

Step 9

- Turn eight ADJUSTABLE GLIDES (25) into the bottoms of the ENDS (S and T) and UPRIGHTS (U and V).

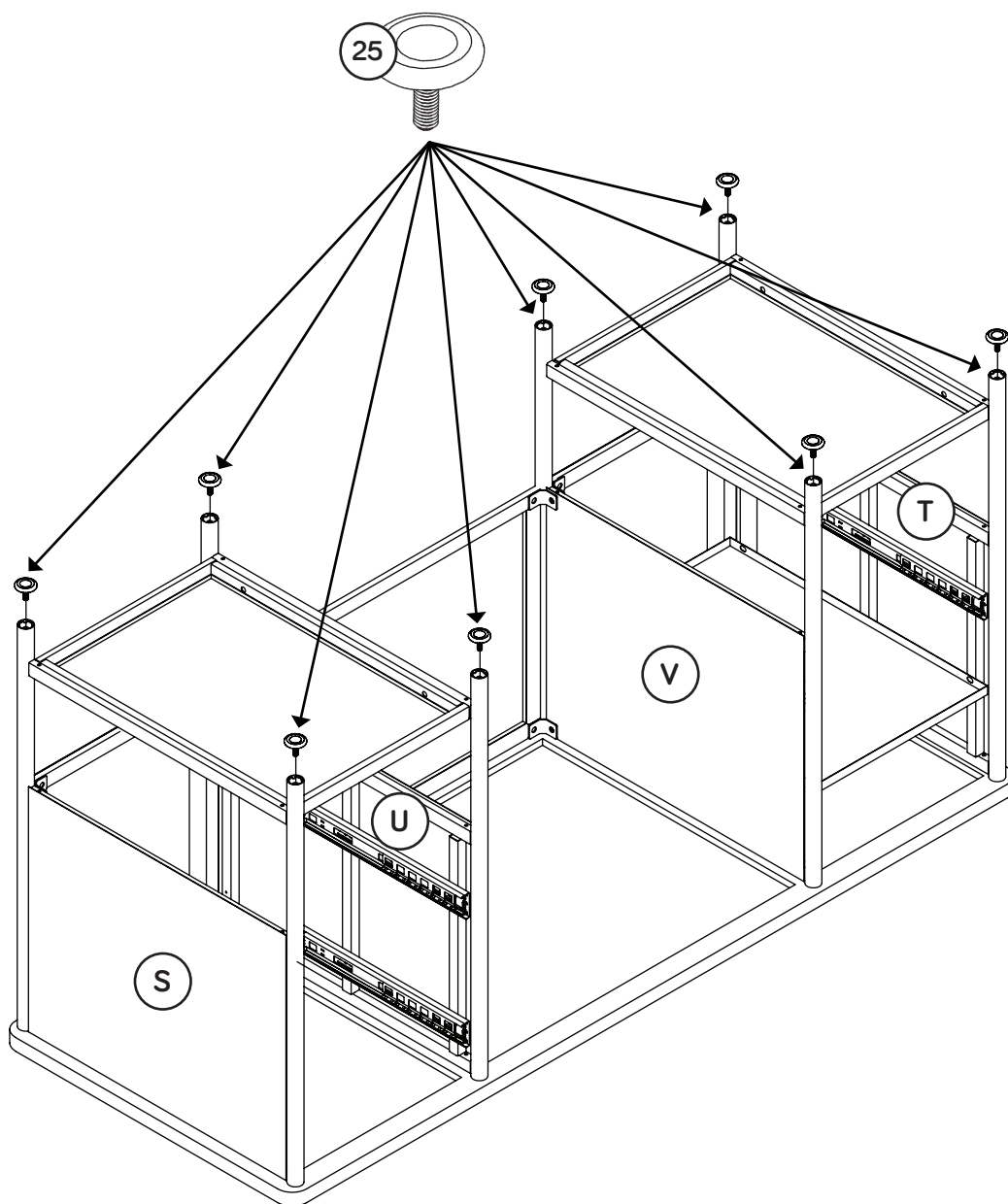

Step 10

1

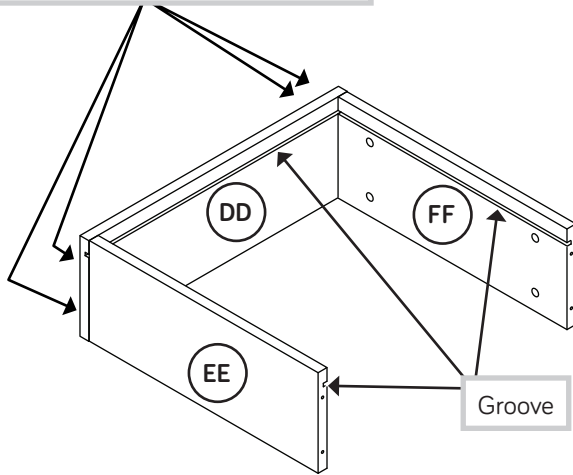
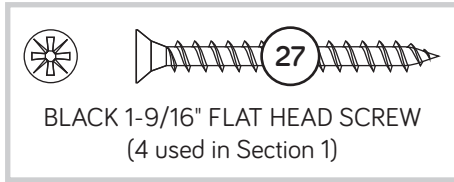

- Fasten one SMALL DRAWER SIDE (DD) to the SMALL DRAWER BACK (EE) and SMALL DRAWER BOX FRONT (FF). Use four BLACK 1-9/16" FLAT HEAD SCREWS (27).

2

Be sure the DRAWER BOTTOM inserts into the DRAWER SIDE groove.

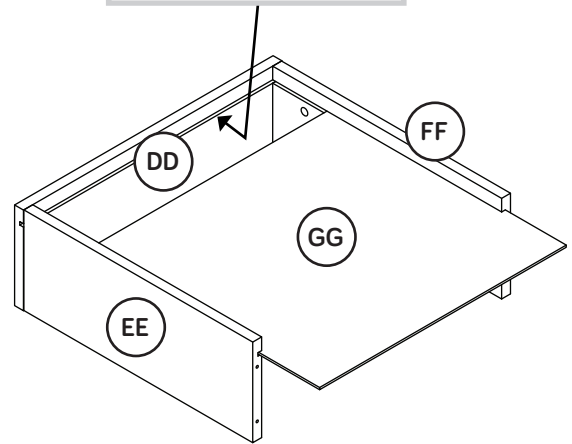

- Slide one DRAWER BOTTOM (GG) into the grooves in the SMALL DRAWER SIDE (DD), the SMALL DRAWER BACK (EE), and the SMALL DRAWER BOX FRONT (FF).

3

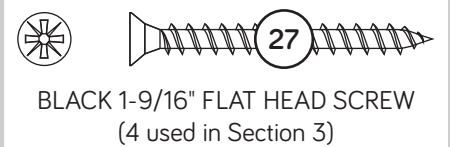
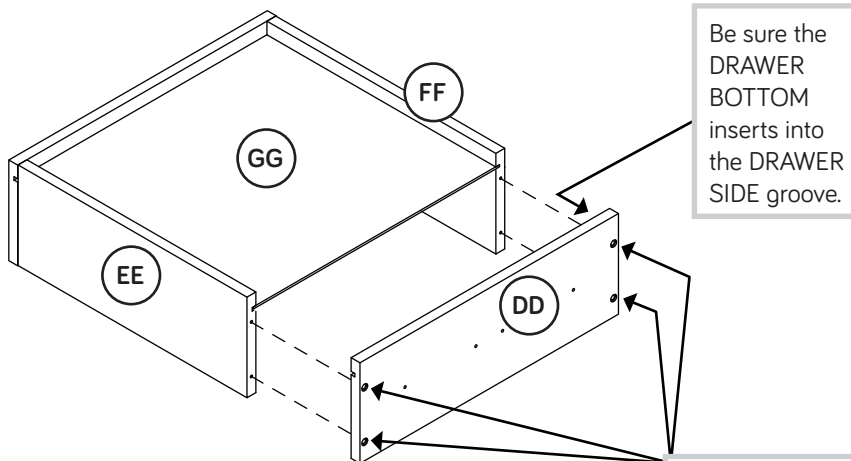

- Fasten the remaining SMALL DRAWER SIDE (DD) to the SMALL DRAWER BACK (EE) and SMALL DRAWER BOX FRONT (FF). Use four BLACK 1-9/16" FLAT HEAD SCREWS (27).

- NOTE:** Be sure the DRAWER BOTTOM (GG) inserts into the groove of the SMALL DRAWER SIDE (DD).

Step 11

First, fasten one PULL (24) to the SMALL DRAWER FRONT (BB). Use two BLACK 3/4" MACHINE SCREWS (31).

Second, fasten the SMALL DRAWER FRONT (BB) to the SMALL DRAWER BOX FRONT (FF). Tighten four BLACK 7/8" HEX HEAD SCREWS (30) using the L-WRENCH (26).

Fasten two EXTENSION SLIDES (21) to the SMALL DRAWER SIDES (DD). Use six SMALL BLACK 1/2" FLAT HEAD SCREWS (33).

NOTE: Use the 1st, 4th, and 7th holes from the OPEN END in the EXTENSION SLIDE.

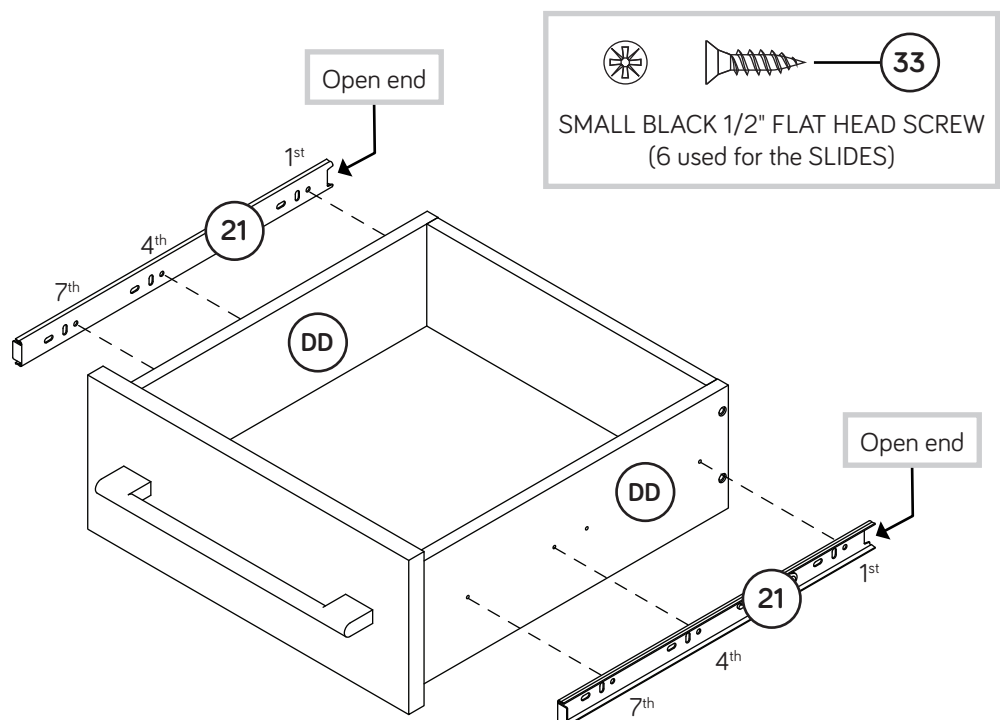
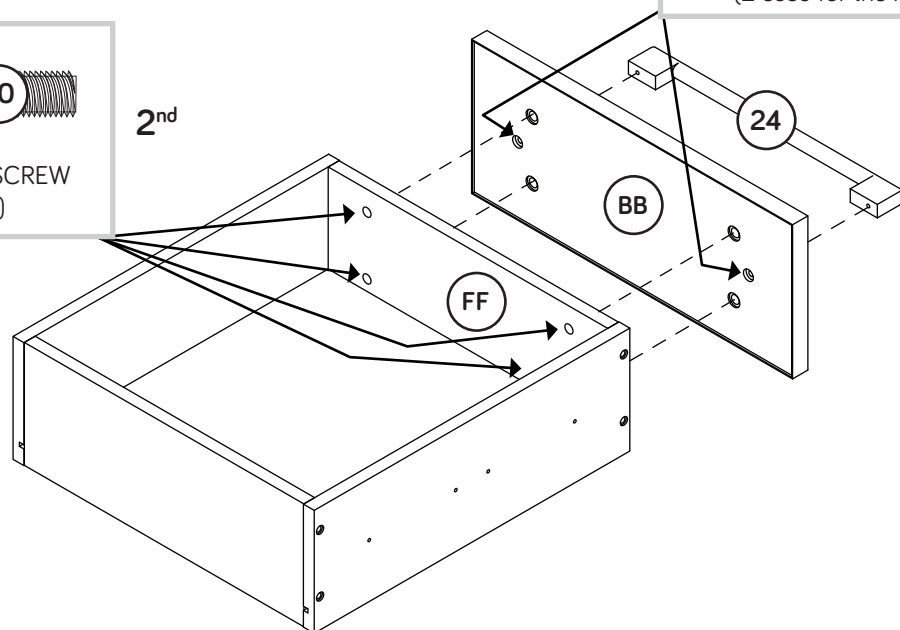
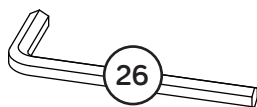
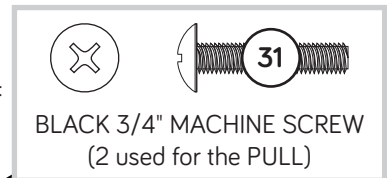
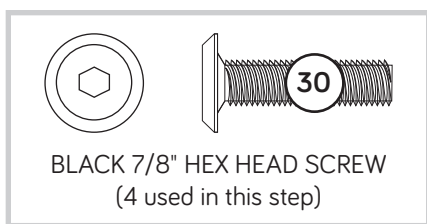

Step 12

1

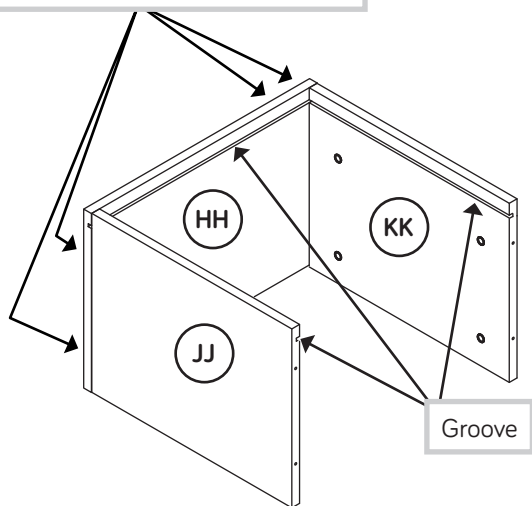
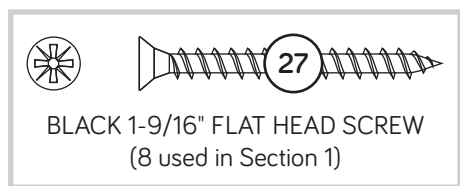

- Fasten one LARGE DRAWER SIDE (HH) to the LARGE DRAWER BACK (JJ) and LARGE DRAWER BOX FRONT (KK). Use four BLACK 1-9/16" FLAT HEAD SCREWS (27).

2

Be sure the DRAWER BOTTOM (GG) inserts into the DRAWER SIDE groove.

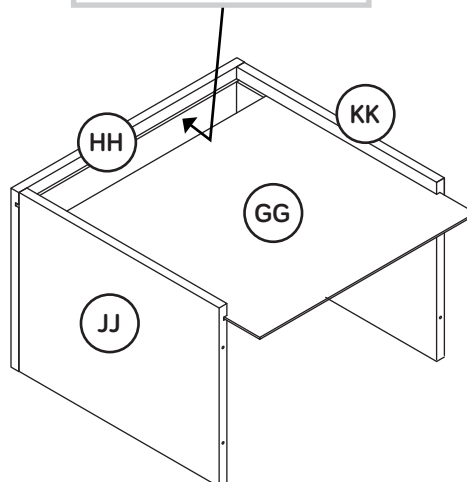

- Slide one DRAWER BOTTOM (GG) into the grooves in the LARGE DRAWER SIDE (HH), the LARGE DRAWER BACK (JJ), and the LARGE DRAWER BOX FRONT (KK).

3

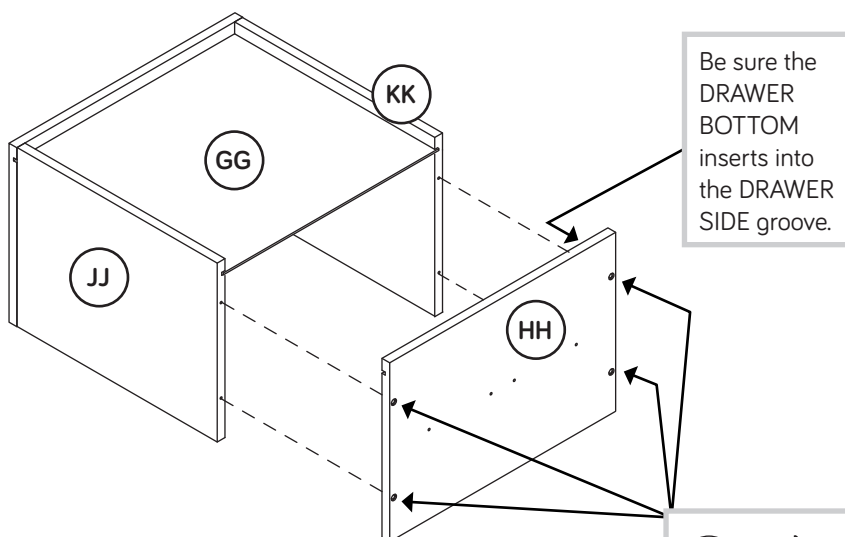

- Fasten the LARGE DRAWER SIDE (HH) to the LARGE DRAWER BACK (JJ) and LARGE DRAWER BOX FRONT (KK). Use four BLACK 1-9/16" FLAT HEAD SCREWS (27).

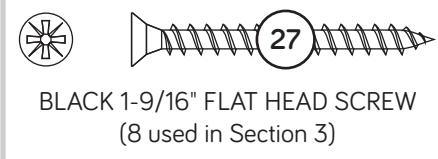

- NOTE:** Be sure the DRAWER BOTTOM (GG) inserts into the groove of the LARGE DRAWER SIDE (HH).

- Repeat this step for the other large drawer.

Step 13

- ✦ First, fasten one PULL (24) to the LARGE DRAWER FRONT (CC). Use two BLACK 3/4" MACHINE SCREWS (31).
- ✦ Second, fasten the LARGE DRAWER FRONT (CC) to the LARGE DRAWER BOX FRONT (KK). Tighten four BLACK 7/8" HEX HEAD SCREWS (30) using the L-WRENCH (26).
- ✦ Fasten two EXTENSION SLIDES (21) to the LARGE DRAWER SIDES (HH). Use six SMALL BLACK 1/2" FLAT HEAD SCREWS (33).
- ✦ **NOTE:** Use the 1st, 4th, and 7th holes from the OPEN END in the EXTENSION SLIDE.
- ✦ Press two FILE GLIDES (22) onto the LARGE DRAWER SIDES (HH). Then place two FILE HANGERS (23) onto the FILE GLIDES (22) as shown.
- ✦ Repeat this step for the other large drawer.

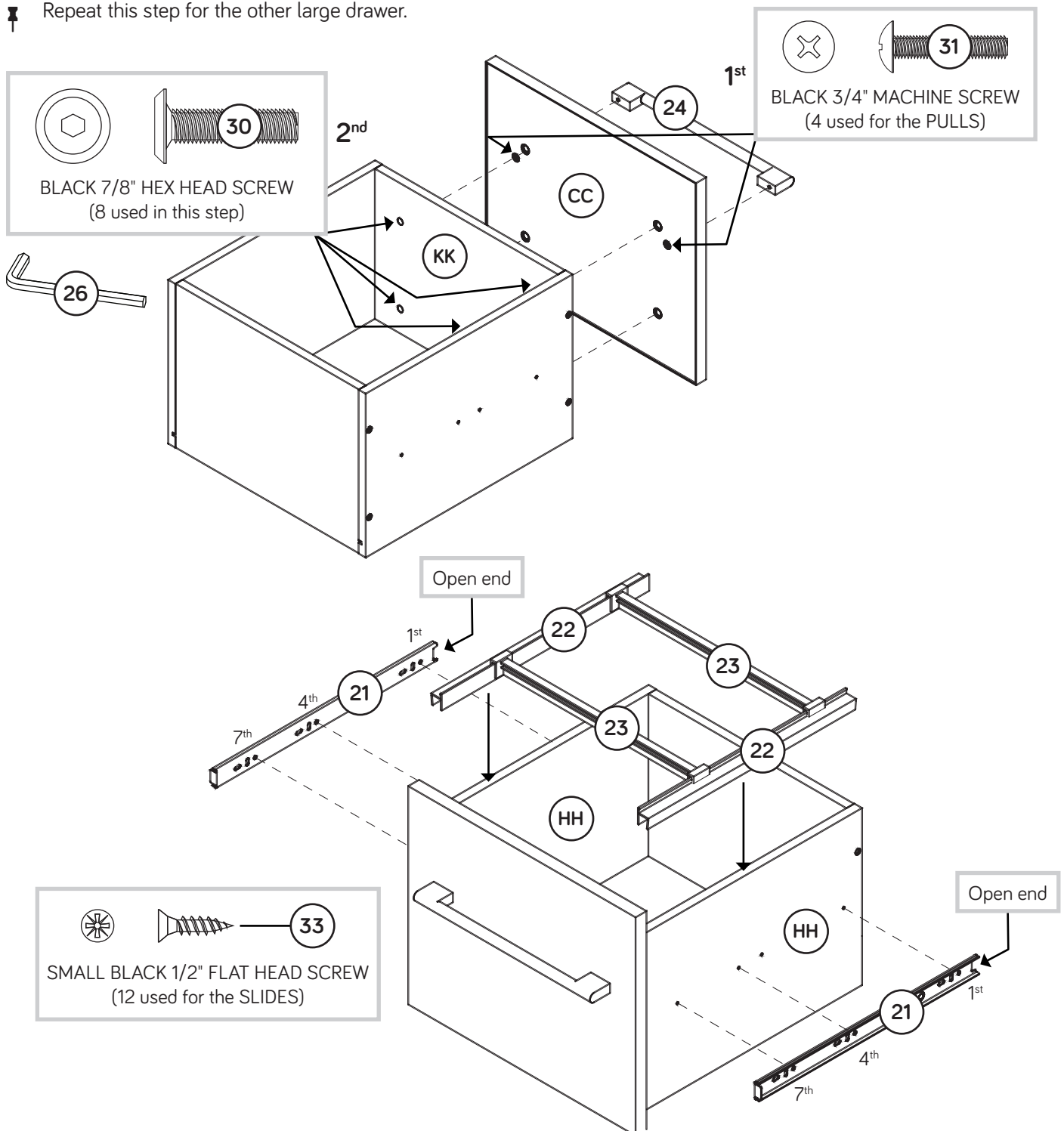

Step 14

- ✦ Carefully stand your unit upright.
- ✦ To insert a drawer into your unit, line up the EXTENSION SLIDES on the drawer with the EXTENSION RAILS on the unit and push the drawer into the unit until the drawer is fully inserted. The drawer will push in hard until it is all the way in, then it will slide in and out easier.
- ✦ To level your unit, turn the ADJUSTABLE GLIDES on the bottom of the unit.
- ✦ NOTE: Please read the back pages of the instruction booklet for important safety information.
- ✦ This completes assembly. Clean with a damp cloth. Wipe dry.

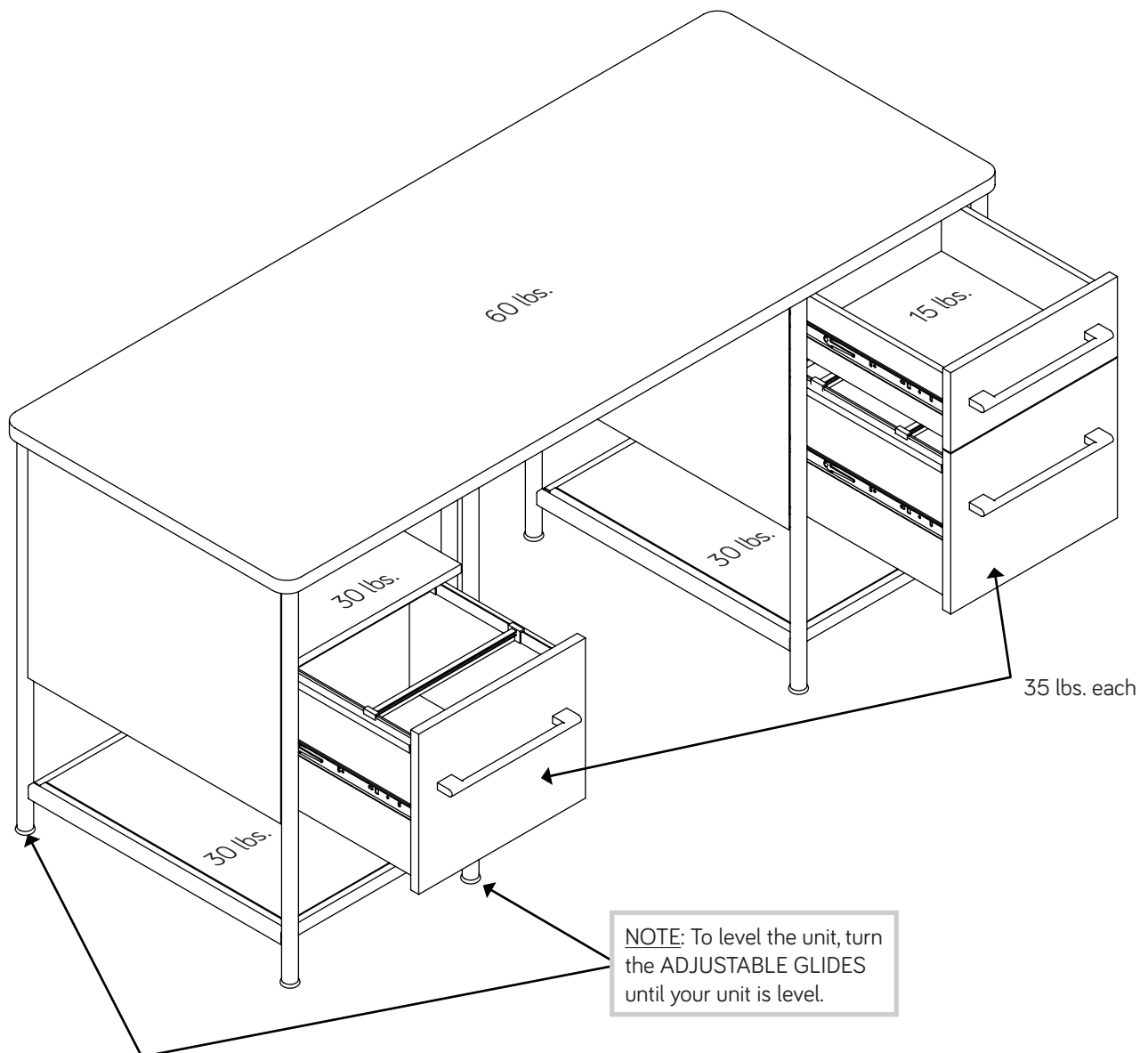

⚠ WARNING

Please use your furniture correctly and safely. Improper use can cause safety hazards, or damage to your furniture or household items. *Carefully read the following chart.*

Look out for:	What can happen:	How to avoid the problem:
<ul style="list-style-type: none">• Overloaded shelves or drawers.• Improper loading can cause the product to be top-heavy.	<ul style="list-style-type: none">• Risk of injury.• Top-heavy furniture can tip over.• Overloaded shelves and drawers can break.	<ul style="list-style-type: none">• Never exceed the weight limits shown in the instructions.• Work from bottom to top when loading shelves and drawers. Place the heavier items on the lower shelves or in lower drawers.
<ul style="list-style-type: none">• Improperly moving furniture that is not designed and equipped with casters.	<ul style="list-style-type: none">• Furniture can tip over or break if improperly moved.• Physical injury. Furniture can be very heavy.• Breakage of tops - particularly with double pedestal furniture (drawers at both ends).	<ul style="list-style-type: none">• Unload shelves and drawers from top to bottom before moving the unit.• Do not push furniture, especially on a carpeted floor. Have a friend help you lift the item and set it in place.• Provide support to the center section of the top when lifting the furniture.
<ul style="list-style-type: none">• Placing TVs on furniture items that are not designed to support a television is hazardous.	<ul style="list-style-type: none">• Risk of injury or death. TVs can be very heavy. Plus the weight and location of the picture tube tends to make TVs unbalanced and prone to tipping forward.	<ul style="list-style-type: none">• This product is not designed to support a television.